

Imperial 1-1/8 OD Gear-type tube bender

INSTRUCTIONS OF USE



Imperial[®]

DEPENDABLE UNDER PRESSURE[™]

APPLICATION

For bending soft and half-hard copper, aluminium brass, steel and other tubing and pipe which had been tempered and is suitable for bending.

PARTS

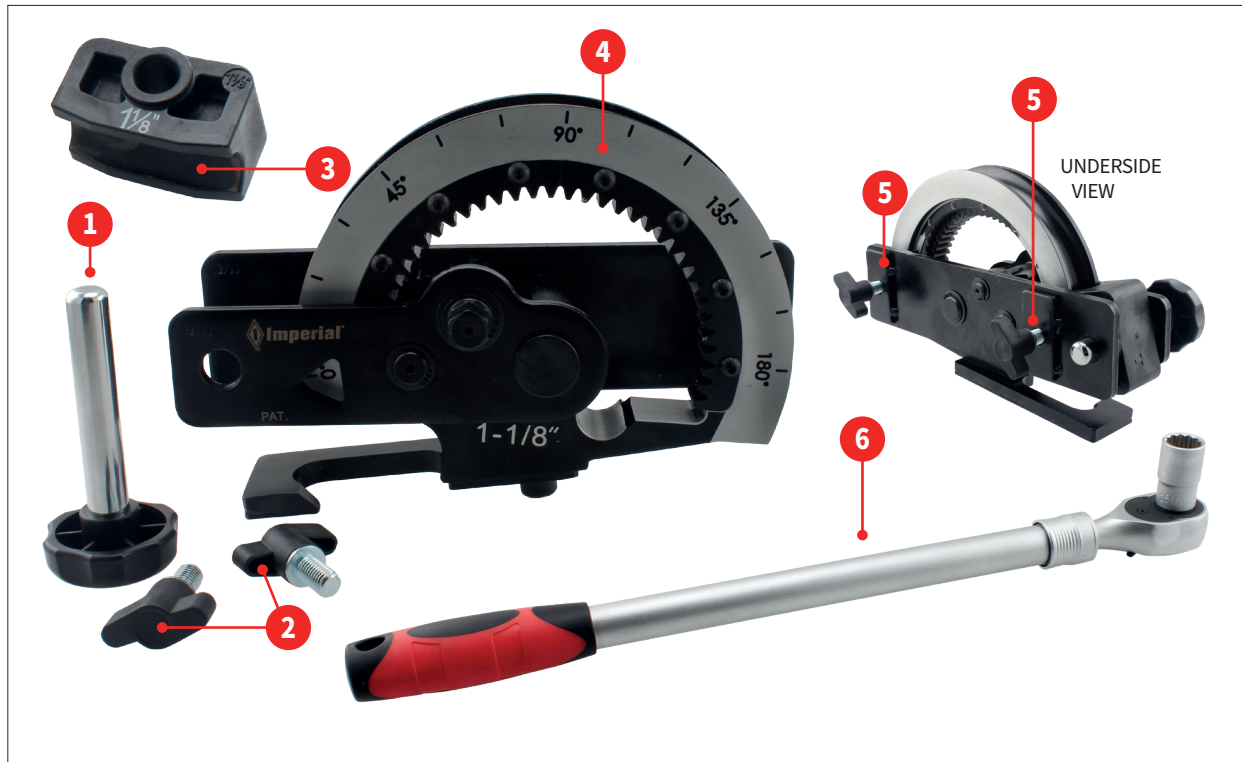

- | | |
|--------------------|--------------------------------|
| 1. Locking pin | 4. Gear bender |
| 2. Securing screws | 5. Mounting points |
| 3. Guide | 6. Ratchet wrench (extendable) |

FEATURES

For 1-1/8" O.D. tubing.

- For 1-1/8in. O.D. tubing
- Full 180° bending radius without repositioning
- Four internal main gears which maximizes engagement and reduces gear slippage producing wrinkle free bends

NB: WE RECOMMEND USING THE IMPERIAL TRIPOD (IMP-270-TRIPOD) WITH THIS BENDER. PLEASE NOTE IMPROPER USE OR MOUNTING COULD DAMAGE THE BENDER AND WILL INVALIDATE THE WARRANTY.

INSTRUCTIONS



MAKE SURE YOU HAVE ALL THE BENDER PARTS IN THE BOX.



ASSEMBLE THE TRIPOD.



SECURE THE TRIPOD TO THE BENDER USING THE SECURING SCREWS.

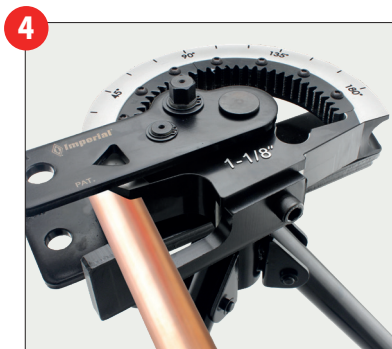

INSERT THE COPPER TUBE AND THEN INSERT THE GUIDE AND LOCKING PIN.

WARNING: THERE IS RISK OF INJURY IF YOU DO NOT KEEP YOUR HANDS AWAY FROM THE CENTRAL GEAR MECHANISM!

INSTRUCTIONS

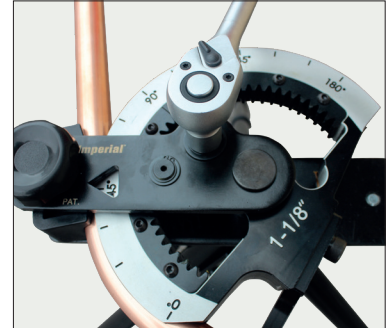

ATTACH THE WRENCH AND USE THIS TO OPERATE THE GEAR BENDER. HOLD THE TUBE WITH THE OTHER HAND. KEEP HANDS CLEAR OF THE CENTRAL GEAR MECHANISM AT ALL TIMES.



ONCE THE DESIRED BEND HAS BEEN CREATED, WIND THE BENDER BACK A FEW TURNS, REMOVE THE LOCKING PIN AND GUIDE TO RELEASE THE TUBE.

WARNING: THESE IS RISK OF INJURY IF YOU DO NOT KEEP YOUR HANDS AWAY FROM THE CENTRAL GEAR MECHANISM!

PART CODES

Code	Item
IMP-270-18-GEARBEND	270-F-18 - 1-1/8 OD gear bender only
IMP-270-TRIPOD	Imperial tripod for gear bender
IMP-270-18-KIT	270-F-18 - 1-1/8 OD gear bender with tripod

SAFETY NOTES

- Ensure that the tripod is on a level surface.
- This is a precision machine for use in tough environments. Make sure that you always use the guide and stopping pins, and keep the working parts clean and in good condition.
- Only genuine spares and accessories should be fitted to this machine.
- Do not try to adapt it yourself.
- Regularly grease the mechanism to improve bending performance and extend the life of your bender.

WARNING: THESE IS RISK OF INJURY IF YOU DO NOT KEEP YOUR HANDS AWAY FROM THE CENTRAL GEAR MECHANISM!

WARRANTY

Any product manufactured by Imperial tools that fails to render service due to defect in workmanship or materials, will be replaced or repaired at no charge. Product failures due to misuse, abuse, normal wear and tear or alterations are not covered by the Limited Lifetime Warranty. Wear items (such as cutter wheels, seals, gaskets, o-rings and gauges) will need to be replaced over time, and are not included. Imperial tools makes no other warranty, expressed or implied. Tools should be returned to the buyer's place of purchase.